

MODEL 3000-1514 and 3000-1518 CURRENT METER

SUSPENSION WAND OPERATING AND MAINTENANCE INSTRUCTIONS

GENERAL DESCRIPTION

The above part numbered devices consist basically of a 1" diameter aluminum tube 12 feet in length (metric version, 3000-1518, is 4 meters in length). The tube is marked in feet and tenths or in meters with 5cm graduations. The graduations begin at the bottom end of the tube. A sliding/locking device (**2100-151-Slider**) positions the Model 3000 Sensor anywhere along the tube and locks the sensor firmly in place while taking measurements. The tube breaks down by means of threaded fittings into four equal-length sections. The Sensor/Cable assembly (**2100-A22**) slips easily in and out of the SLIDER for transporting and storing the sensor wand. The sensor wand fits into a PVC tube supplied for transportation and storage.

INSTRUCTIONS FOR USE

1. Place **SLIDER** onto a section of the tube orienting the sensor cable slot toward the top of the rod.
2. Thread the tube sections together as required for the desired depth measurements. (NOTE: Plastic "thread protectors" are installed when the wand is shipped and must be removed before wand assembly can take place. Keep the thread protectors for later use when the wand is taken apart for transport and storage.
3. Thread the **TOP CAP** onto the top section of the assembled wand. It will fit any section. The **TOP CAP** contains the directional pointer in a stored position (it also has spare 6-32 set screws and an allen wrench for use with the set screws). Grasp the knurl on the stored pointer and unscrew it from the **TOP CAP** then thread it into the horizontal "pointing position" in one of the two threaded holes provided.
4. The **SLIDER** is locked into position on the rod by use of the knurled nut located at the back of the slider. Do not tighten the nut excessively as it is not necessary for keeping the slider in position. The 10-32 screw located in the center of the locking nut may be used to attach a flow direction "streamer" if desired. Orient the slider in the same direction as the Top Cap pointer if the sensor will be in depths where you cannot see the propeller.
5. Insert the Model 3000 Sensor (2100-A22) in the Slider and lock it into place with the set screw. **BE SURE THAT THE SENSOR BODY IS PROPERLY ORIENTED SO THAT THE SET SCREW FITS ONLY INTO THE RECESS PROVIDED FOR IT.** Tightening the set screw on the sensor body in a place other than in the recess may damage the sensor or the cable.
6. After the Rotor (2100-A21) has been installed on the sensor body, loosen the **SLIDER** lock nut and point the propeller in the same direction as the pointer at the top of the wand. Move the slider to the desired measuring depth and tighten the lock nut.
7. Attach the **FOOT** to the bottom section of the wand by means of the -28 stainless steel bolt. The **FOOT** has a hole in it (off center) which is designed for attaching a steadying lanyard when high flow rates make handling difficult.

TAKING READINGS

1. Connect the 3000 Indicator to the Sensor by use of the twist-lock connector. Turn on the Model 3000 indicator and press the COUNT button. Confirm that the display counts up sensor pulses (four per revolution) and that the propeller rotates very freely.
2. Go to either the VELOCITY mode or the DISCH mode by pressing the appropriate keys.

- Place the sensor wand in the stream orienting the propeller into the flow.
- The Model 3000 Indicator will display the stream velocity. (For more complete Indicator operating instructions see the accompanying **Model 3000 Indicator Operating Instructions.**)

MAINTENANCE OF THE SENSOR WANDS

- Never leave the tube sections threaded together after use. Normal corrosion of the aluminum material could "freeze" the joints and make disassembly difficult or impossible later. For best results keep the threads and the shaft below the threads **VERY CLEAN** and well lubricated with a medium weight oil or grease. Silicone grease or petroleum jelly will work.
- Always make sure the threads as well as the bore of the mating section of the tube are **completely free of all dirt and other particles** before re-mating the sections. The fit is necessarily close at the joints so great care must be used when assembling the sections to prevent threaded parts from seizing. **NEVER FORCE PARTS TOGETHER !! And remove all traces of dirt and debris before assembling the sections.**
- Always replace the Thread Protectors after disassembly of the wand.
- ALWAYS Remove the Sensor from the Slider when transporting the wand to avoid damage to the Sensor and Rotor Assembly.*
- Remove the Complete Rotor Assembly from the Sensor when transporting to prevent damage to the propeller and the Fiber-Optics Rotor.

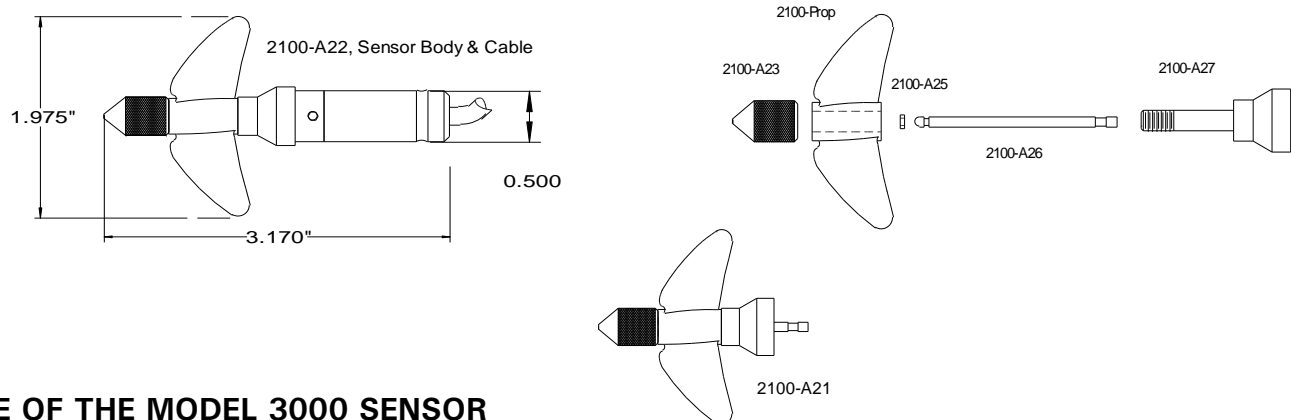

CARE OF THE MODEL 3000 SENSOR

The Sensor of the *Model 3000* Current Meter is the single most important part of the instrument and great care must be observed for its continued accurate output.

Keep the Sensor/Propeller assembly above the stream bed when taking readings and avoid rocks and other hazards when moving from one measuring site to another. This will prevent damage to the Rotor, Rotor Shaft, Propeller and the Sensor Body.

Never transport or store the sensor wand with the propeller rotor installed. Use the 1/16" hex screwdriver to *loosen the setscrew and always remove the entire rotor assembly when not using the Model 3000.* Don't just remove the propeller, remove the whole rotor.

Always replace the batteries in the Model 3000 Indicator with fresh ones.

- During rough use check the propeller frequently for frayed leading edges and for cracks. Chipped or cracked props should be replaced. Frayed leading edges can be brought back to acceptable levels of operation by reshaping them with 150 grit (or finer) sandpaper. Propellers which show signs of being bent or misshapen should be discarded.

2. Rotational friction is by far the biggest cause of erroneous data especially at velocities below 2 feet per second. Check the freedom of rotation frequently especially in turbid water or after rough handling. In some measuring situations it may be necessary to completely disassemble the rotor and clean the parts with clear water after each immersion. Use spare rotor assemblies and interchange them often. ***Never leave the rotor assembly attached to the sensor after taking readings.***
3. Water is the lubricant for the 2100 rotor. "Canned air" and spray type degreasers should be used to regularly clean the "bore" of the Rotor (2100-A27) and the polished surface of the Rotor Shaft (2100-A26). Avoid oil & grease if possible.
4. The Rotor Assembly (2100-A21) should spin very freely when held in the vertical position (propeller pointing up) and simply blow lightly on the propeller. If it does not, clean the bore of the Rotor and the surface of the Rotor Shaft thoroughly.
One method to determine an acceptable level of low-velocity performance by a particular Rotor Assembly is to perform a "Spin Test" :
Install the Rotor on the sensor, connect the sensor to the Indicator, and place the Indicator in the **COUNT** mode. With the propeller pointing up blow very hard straight down on the propeller. *At the instant you stop blowing* hit the **RESET** button on the indicator and allow the rotor to coast to a stop. A rotor which will perform to the low velocity limits of its design produces counts on the indicator of at least 300.
5. If the Rotor begins to "buzz" when spun by hand it means that the bore diameter of the Rotor (2100-A27) and the outside diameter of the Shaft (2100-A26) are too far apart. In this case it is advised to replace the Rotor with a new one. If the shaft shows visible signs of wear replace it also. Severe buzzing indicates that the rotor is bouncing off the shaft as it rotates around it. This slows the rotor significantly especially at velocities above 3 FPS and will cause readings to be slower than actual. **Note:** Some slight buzzing may be heard in the later versions of the rotor when it is spun "dry". This buzzing should cause no significant loss of efficiency.
6. Periodically examine the Thrust-Bearing Nut (2100-A23) and check inside on the bottom (the bearing surface). If a pronounced "cup" begins to form (wear from the ball-shaped end of the Rotor Shaft) the 2100-A23 should be replaced. This is especially necessary when using the *Model 3000* in low-flow situations, 2 FPS or lower.
7. The Photo-Optics in the sensor body must be kept clean. Use soap and water and a soft tooth brush to keep the "eyes" clean if necessary. *Be careful and do not scratch the Photo-optics as this could cause unwanted light scattering and therefore erroneous readings.* Likewise the Fiber optics "eyes" in the base of the Rotor (2100-A27) should also be kept clean.

Treat the 2100 Rotor Assembly and Sensor with care and it will continue to produce accurate data with minimum maintenance.

SWOFFER INSTRUMENTS, INC.
13704 24th St E, #A108
Sumner, WA 98390 U.S.A.
(253) 661-8706
www.swoffer.com

